

NRF24L01 and LABVIEW based Multi-channel Data acquisition system for Managerial Dash Board (MDB) in LISCO.

Authored By:

- **Yousif Kalifa Hawil**

Computer Systems and Telecommunications Department - Libyan Iron and Steel Company (LISCO).

- **Prof : Marai Mohammed Abousetta.**

School of Applied Sciences and Engineering - The Libyan Academy.

Abstract.

This paper introduces a wireless Data Acquisition System based on NRF24L01 and LABVIEW, which can be used for Managerial Data collection in the harsh environment of industrial production in LISCO . The proposed system hardware mainly include wireless transmission module NRF24L01 and A/D data acquisition module, which is A/D conversion part of the chip STM32C8T6 built-in ADC. The laptop computer uses LABVIEW as the hosting computer for data display and processing. The proposed wireless A/D acquisition system has stable operation, long transmission distance, accurate data transmission, no loss of data, and can be adapted to various industrial control and measurement situations through measurement in different harsh environments in LISCO.

1 Introduction

Data acquisition is the process by which physical phenomena from the real world are transformed into electrical signals that are measured and converted into a digital format for processing, analysis, and storage by a computer. [1] In a Data acquisition system the real-world signals physical phenomenon or physical property such as temperature, light intensity, gas pressure, fluid flow, force etc. is measured. Regardless of the type of physical signal to be measured it is first transformed into an electrical form such as voltage by sensors and transducers. A data acquisition system can be functionally divided into two main parts:

- **The Analog Front End (AFE)**
- **Digital Signal Processing**

The analog front end comprises of the signal conditioning hardware which makes the signal suitable to interface it to the Analog to Digital Convertor (ADC). It consists of comparators, Operational amplifiers, filters, switches, electrical isolators, sensors and

actuators, etc. Some DAQ devices include built-in signal conditioning designed for measuring specific types of sensors. The second part of the circuit is the digital signal processing comprises of ADC, microcontroller, memory, drivers etc. This part digitizes signals, processes the signal to meaningful units, scales acquired signal and calibrates overall system to minimize errors and display the results. The DAQ hardware may communicate results to a PC. Data collection for MDBs In LISCOs industrial plants with harsh environmental conditions need multi-channel analog data collection technology for the industrial plants in real time, If the traditional RS232 or RS485 is used, wiring, a complicated wiring work. In view of the above mentioned problems, a wireless Data acquisition system based on NRF24L01 and LABVIEW is proposed. There are two wireless modules are used to realize short-distance communication, which greatly simplifies the circuit, and has low cost and good performance. In addition, the STM32F103 series MCU is smaller than the traditional 51 MCU, and has a small chip size and an ADC with its own interference ability. It has rich internal resources and can adapt to complex industrial environments. In addition, virtual instrument as a milestone in the development of measurement and control instruments, the use of Labview instead of the traditional test instrument greatly facilitates the processing of data[1,2,3].

2 Overall design Concept

The overall structure concept of the whole system is shown in Figure 1. It is divided into A/D data acquisition module (including the minimum system of MCU and various sensor modules or data acquisition cards that can output analog signals). The two wireless transmission modules are respectively in the data acquisition module. Connected to the USB to serial port module (both can receive and send data), the computer software module on the computer side, wherein the computer end is connected to the wireless module through the USB to serial port module, and the serial port will collect more in the LABVIEW. The road A/D conversion data is displayed in real time.

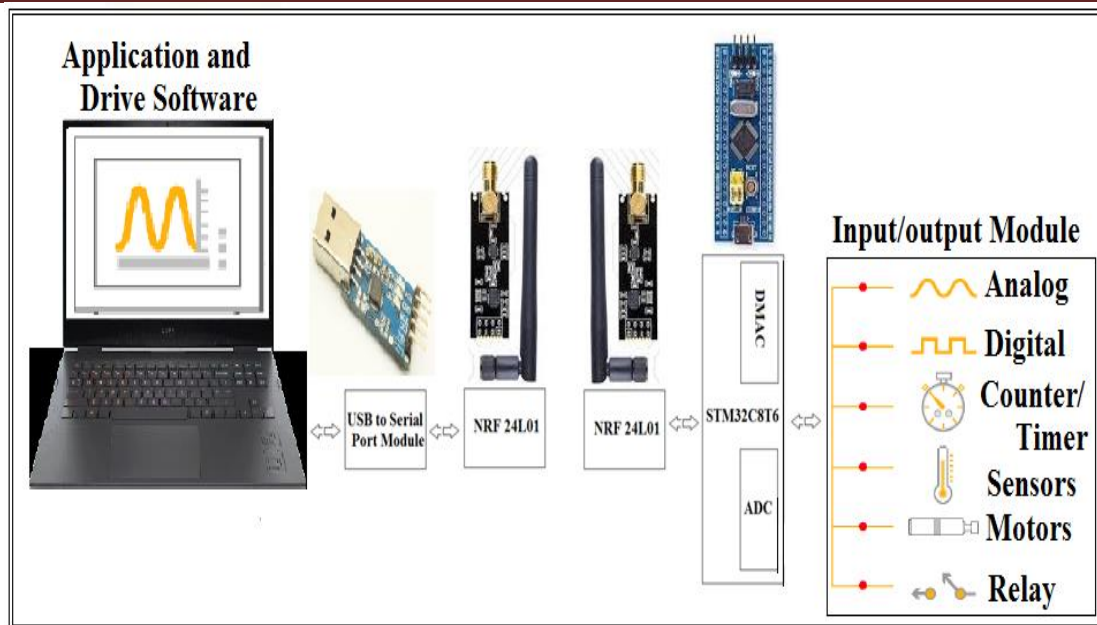

Fig. 1 : System Hardware Architecture

3 Hardware Design Concept

3.1 Data acquisition module

Since there is a limited I/O port resources needed, the STM32F103C8T6 chip based on the ARM Cortex-M3 core series is selected as the control chip. Its has a maximum speed of 72MHz, 37 available I/O ports, 64K FLASH, 10 channels. 12-bit A/D converter, 2 IIC bus, 2 SPI bus, 3 16-bit timers, and a PWM advanced timer for motor control. In addition, the chip's operating voltage is about 3.3v, with sleep and standby modes, which can reduce power consumption to the greatest extent. Since the chip integrates a 10-channel 12-bit ADC, the complexity of the hardware circuit can be reduced. In addition, a USB to serial port module has be installed on the computer to facilitate the data received by the wireless module to be sent to the host computer through the serial port, so that wireless communication can be realized within a short distance[4].

3.2 Wireless Communication Unit

The wireless communication Unit is an important part of data transmission. To ensure a good quality of data transmission, the NRF24L01 wireless transceiver Unit is selected. The operating voltage required for this wireless Unit is in the range between 1.9 and 3.6V, power consumption is low and the Unit volume is small. NRF24L01 integrates high-speed signal processing part related to RF protocol RF. For example,

the lost data packet can be automatically retransmitted and automatically generate a response signal after receiving the transmission data. The NRF24L01 uses the SPI interface to communicate with the MCU. The high-end MCU can communicate with the wireless Unit through the built-in hardware SPI port.. The schematic diagram of the wireless Unit is shown in Figure 2. The NRF24L01 has a total of eight pins. The first pin is GND, the second pin is VCC, and the third CE pin is used to configure the working mode of the wireless Unit. The next four pins are connected to the SPI hardware interface of the STM32. These four pins are NSS (slave device select pin), SCK (clock signal pin, as master output, slave input), MOSI (master out/slave), and MISO (master/in/ From the out pin). The last pin is an interrupt pin that is used to generate an interrupt request to the STM32[5,6].



Fig. 2:NRF24L01 wireless Unit.

4 System software Conceptual design

4.1 Data acquisition module Conceptual software design

In the entire A/D data acquisition system, the program uses KEIL software as the development environment, based on the STM32 v3.5 firmware library and written in C language. Because ADC data with multiple channels needs to be sent to the host computer in time, the combination of DMA and ADC is used to collect data. By the addition of the DMA mode, high-speed data transfer can be automatically performed between the peripheral sensor or the data acquisition card and the memory. and no CPU is required to participate, data can be quickly moved to memory by setting the

DMA channel, which saves CPU resources and allows the CPU to handle other tasks. Since the STM32's ADCs are all 12-bit, since the number of data bits for serial communication is set to 8 bits, the upper four bits of the collected data are transmitted first, and then the lower eight bits are transmitted. The values of the four channels are stored in an array, and the data collected by A/D ranges from 0 to 4096. The entire software work flow chart is shown in Figure 3.

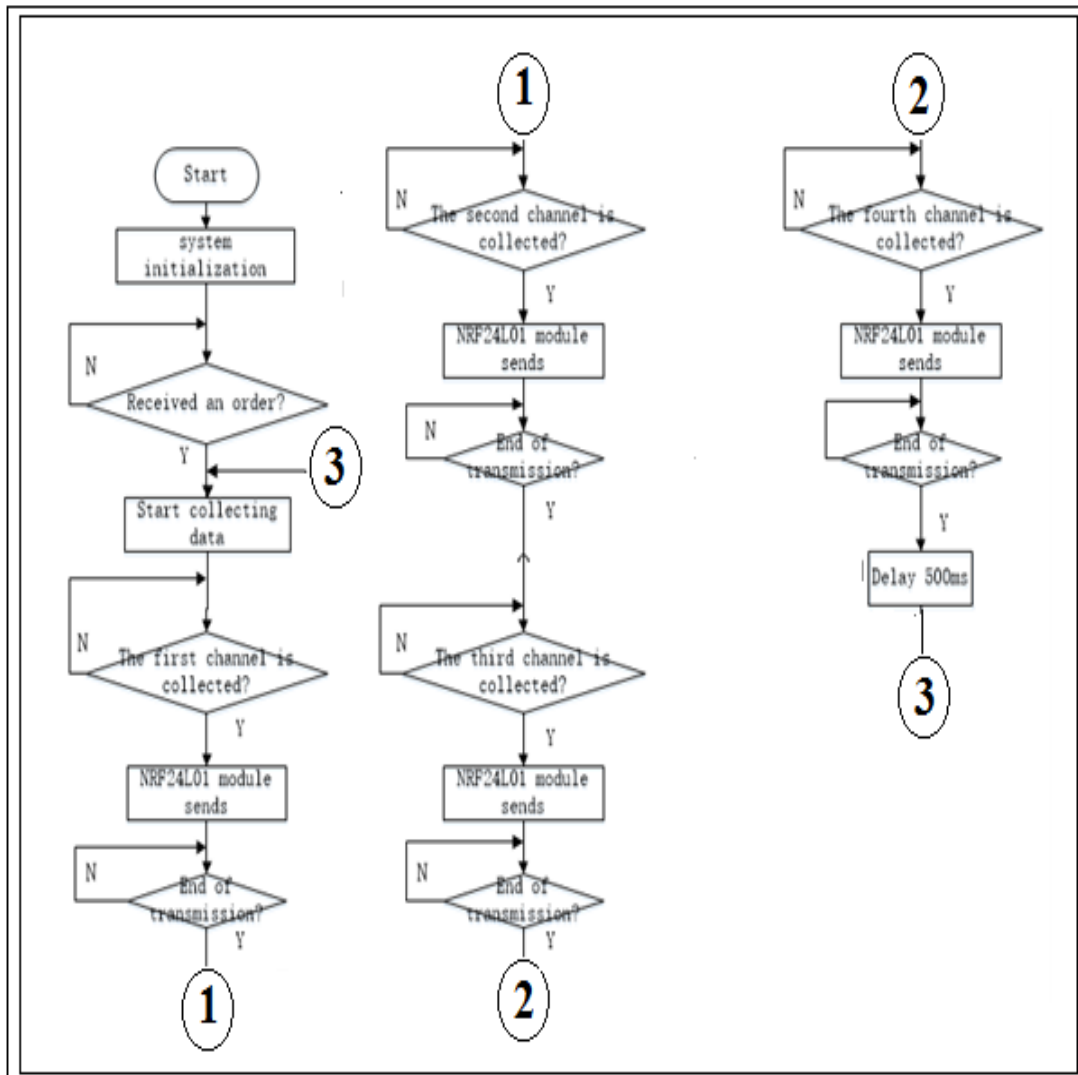

Fig. 3 :Software flow chart.

4.2 Wireless transceiver Unit Conceptual software design

The NRF24L01 uses the SPI interface for communication. SPI is a high-speed, full-duplex, synchronous communication bus that occupies only four lines of the chip and has a simple structure. In point-to-point communication, the SPI interface does not require addressing operations and is full-duplex communication with high

transmission efficiency. There are four working modes of SPI. Here, SPI0 mode is adopted, that is, CPOL=0 and CPHA=0. CPOL determines whether the idle state of the clock signal is high or low. CPHA determines the sampling time. In SPI0 mode, the Unit will sample the data on the rising edge of each clock cycle. The data acquisition is set from the highest bit. send. At initialization, the NRF24L01 is configured to both receive and transmit. Set its data receiving address, effective data digits, communication channel, data transmission rate and transmission power. The workflow of sending and receiving data is shown in Figure 4 [7].

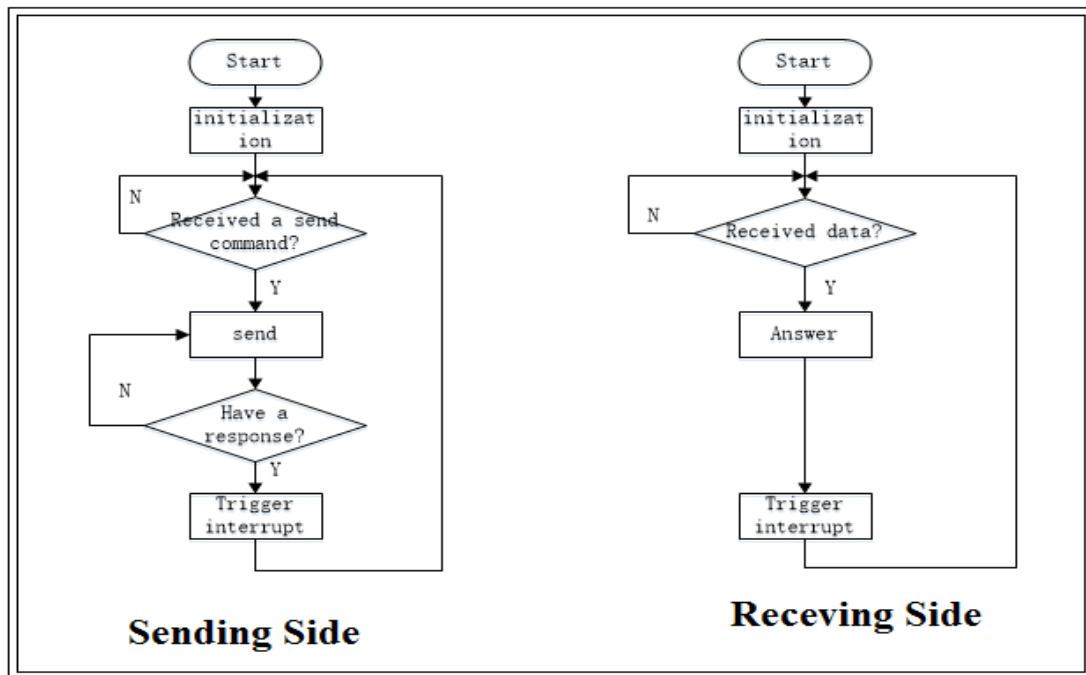

Fig. 4 : flow chart of wireless Unit sending and receiving data.

4.3 Computer-side software design

National Instruments (NI)'s are used by the computer as graphical programming software LABVIEW to serve as a development environment. With the powerful visual programming capabilities of LABVIEW, virtual instrument testing platform can be quickly and easily built. The wireless data receiving unit is connected with the USB to serial port module, and then can communicate with the host computer through the RS232 serial port protocol. The block diagram of the entire LABVIEW system program running is shown in Figure 5 [8].

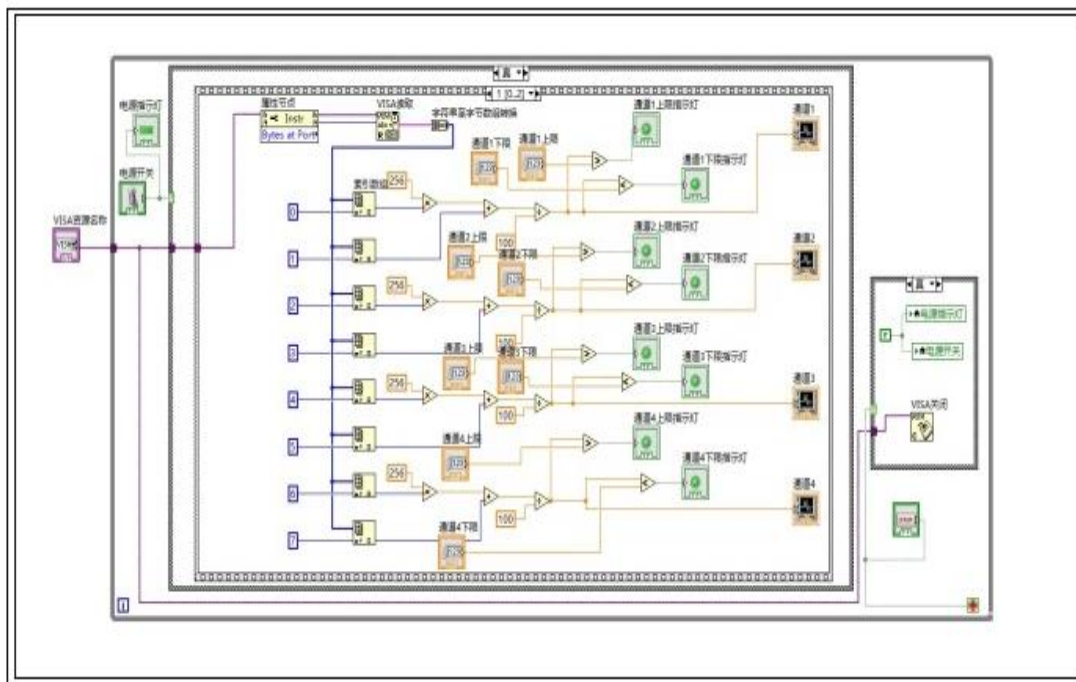

Fig. 5 : LABVIEW program block diagram.

5 Testing and analysis

Connect the core board and the sensor or data acquisition card to the analog input port of the STM32 MCU, connect the wireless transmission Unit to the SPI hardware interface of the STM32, and connect to the wireless receiving Unit through the USB to serial port on the computer. When Labview software is opened, the waveform graph begins to plot the value of the acquired data into a voltage. The data collected by each channel is displayed independently in a graph to avoid interference between different channels. The collected data can also be exported to an Excel file for easy transmission to different engineers for viewing. At the same time, the upper and lower limit indicators are set on each channel. When used, the upper and lower limits of the corresponding channel on the software front panel can be set. Once the set upper limit threshold or the lower limit threshold is exceeded, the indicator light It will light up to remind the technician that there is an abnormality, and multiple channels operate independently without interfering with each other. The experimental phenomenon is shown in Figure 6. The data collected is shown in Figure 7.

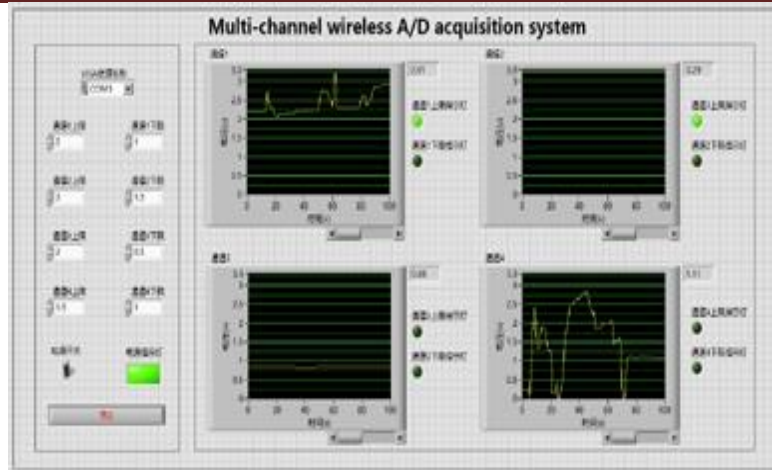

Fig. 6 : A/D data real-time display.

Time (s)	Channel 1 = voltage (v)	Channel 2 = voltage (v)	Channel 3 = voltage (v)	Channel 4 = voltage (v)
1	2.2	3.29	0.66	0.24
2	2.21	3.29	0.66	0.24
3	2.2	3.29	0.66	0.23
4	2.21	3.29	0.66	0.26
5	2.2	3.29	0.66	0
6	2.21	3.29	0.66	0.92
7	2.21	3.29	0.66	1.7
8	2.21	3.29	0.64	2.41
9	2.21	3.29	0.64	2.39
10	2.21	3.29	0.66	1.58
11	2.21	3.29	0.66	1.58
12	2.21	3.29	0.66	1.35
13	2.21	3.29	0.65	1.69
14	2.77	3.29	0.65	1.87
15	2.42	3.29	0.65	1.88
16	2.29	3.29	0.65	1.65
17	2.29	3.29	0.66	1.64
18	2.3	3.29	0.66	1.27
19	2.15	3.29	0.66	1.28
20	2.09	3.29	0.66	1.28
21	2.09	3.29	0.67	0.16
22	2.11	3.29	0.66	0.15
23	2.13	3.29	0.66	0.15
24	2.13	3.29	0.67	0.44
25	2.14	3.29	0.66	0
26	2.15	3.29	0.66	0
27	2.15	3.29	0.66	0.28
28	2.15	3.29	0.67	0.32
29	2.16	3.29	0.66	1.13

Fig. 7 : Data collection.

6 Conclusion

This paper is an introduction to a multi-channel wireless A/D acquisition system based on NRF24L01 and LabVIEW which can be adopted to managerial Key Performance Indicators (KPIs) in Libyan Iron and Steel Company (LISCO) . The proposed system solves the problem of complicated hardware and high cost when using traditional wired connection, the system has high integration, small volume and a good real-time performance, and can work well under severe industrial environmental conditions. It can be embedded in various occasions where A/D data collection needs to be performed in real time, and has a high promotion and use value.

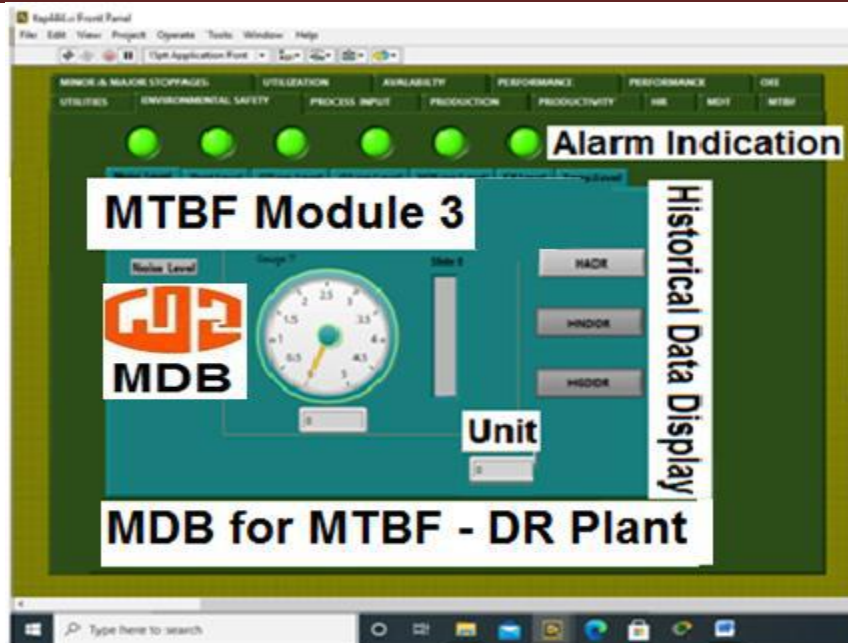

Fig. 8 : HMI Testing of Industrial Machine MTBF as a Managerial KPI.

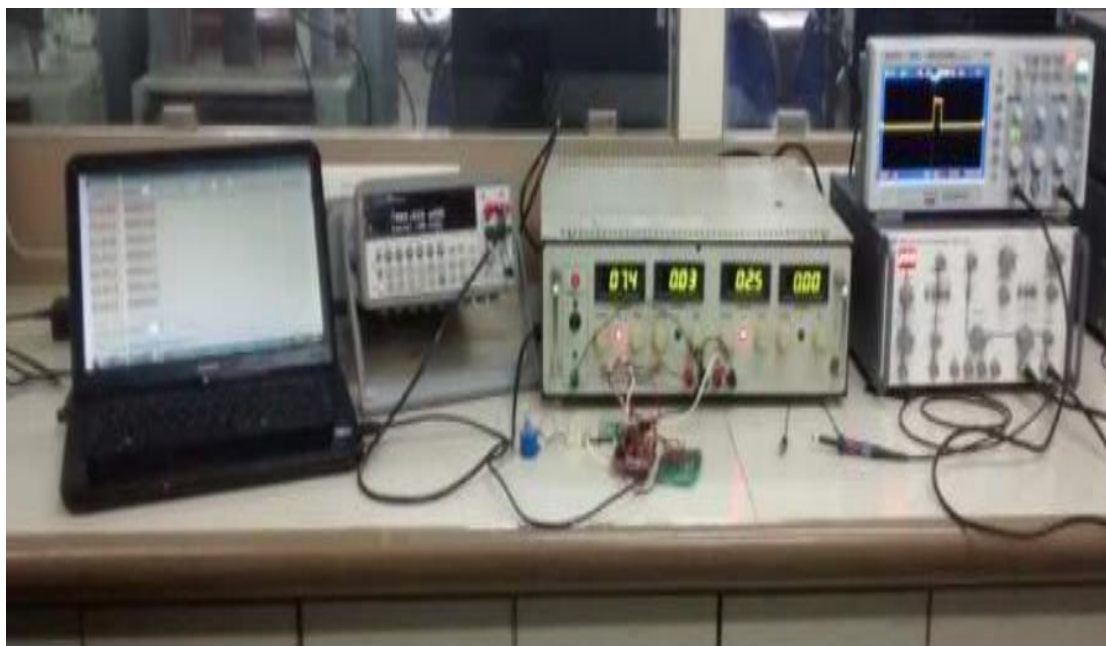

Fig. 9 : Testing Requirements.

References :

- [1] Sun Wen. Design and implementation of multi-channel data acquisition system. Hunan University, 2013.

- [2] Li Xing, Huang Xiaoli, Hu Bing, Liu Xijun. Wireless intelligent temperature monitoring system based on nRF24L01. Instrument Technology and Sensors, 2011.
- [3] Gu Wenwu, He Qingzhong, Zhou Tie, Zhang Yanling. Based on LabVIEW and Intelligent Instrument Data Acquisition System. Instrument Technology and Sensors, 2012.
- [4] Wang Chenhui, Wu Yue, Yang Kai. Design of multi-channel data acquisition system based on STM32. Electronic Technology Application, 2016.
- [5] Chen Cheng, Li Ruixiang, Liu Tingting, Liu Yi. Research on wireless data transmission system based on nRF24L01. Electronic Science & Technology, 2016.
- [6] Ma Wei, Yan Dongxing, Zhang Shaojie. Wireless temperature and humidity test system based on nRF24L01[J]. Electronic Design Engineering, 2012, 02: 64-66.
- [7] Zhu Huiyan, Lin Lin. Design of wireless communication system based on MCU and nRF24L01. Electronic Science & Technology, 2012.
- [8] Lü Xiangfeng, Gao Honglin, Ma Liang, Wang Xinhua. Research on Serial Communication Based on LabVIEW. Foreign Electronic Measurement Technology.
- [9] John Park, Steve Mackay —Practical Data Acquisition for Instrumentation and Control Systems, 2003.
- [10] Signal conditioning Wikipedia encyclopedia, https://en.wikipedia.org/wiki/Signal_conditioning
- [11] Walt Kester, —Which ADC Architecture is right for your Application?, Analog Devices, <http://www.analog.com/library/analogDialogue/archives/39-06/architecture.pdf>.
- [12] Yang Fubao. Research and design of data transmission system based on Zigbee. Manufacturing Automation, 2011.
- [13] Sun Xueyan. Greenhouse measurement and control system based on Zigbee wireless sensor network. Instrumentation Technology and Sensors, 2010.
- [14] Liu Yang. Research on mine wireless sensor network based on Zig Bee technology. Taiyuan: Taiyuan University of Technology, 2010.
- [15] M. A. Mazidi, J.G. Mazidi, R. D. Mckinlay, —The 8051 Microcontroller and Embedded Systems: using Assembly and C, Pearson Education, Inc., 2nd edition 1999.
- [16] Walt Kester, —MT020-ADC Architectures II- Successive Approximation ADCs, Analog Devices,

<http://www.analog.com/media/en/training-seminars/tutorials/MT-021.pdf>

[17] Walt Kester, — MT020-ADC Architectures III- Sigma Delta ADC, Analog Devices, <http://www.analog.com/media/en/trainingseminars/tutorials/MT-022.pdf>

[18] Jim LeClare, —A Simple ADC Comparison Matrix- Tutorial 2094, Maxim Integrated , <http://www.maximintegrated.com/en/appnotes/index.mvp/id/2094>

[19] Manas Kumar Parai, Banasree Das, Gautam Das —An Overview of Microcontroller Unit: From Proper Selection to Specific Application, International Journal of Soft Computing and Engineering (IJSCE) ISSN: 2231-2307, Volume-2, Issue-6, January 2013